

Figure 1. Component Layout – Bottom

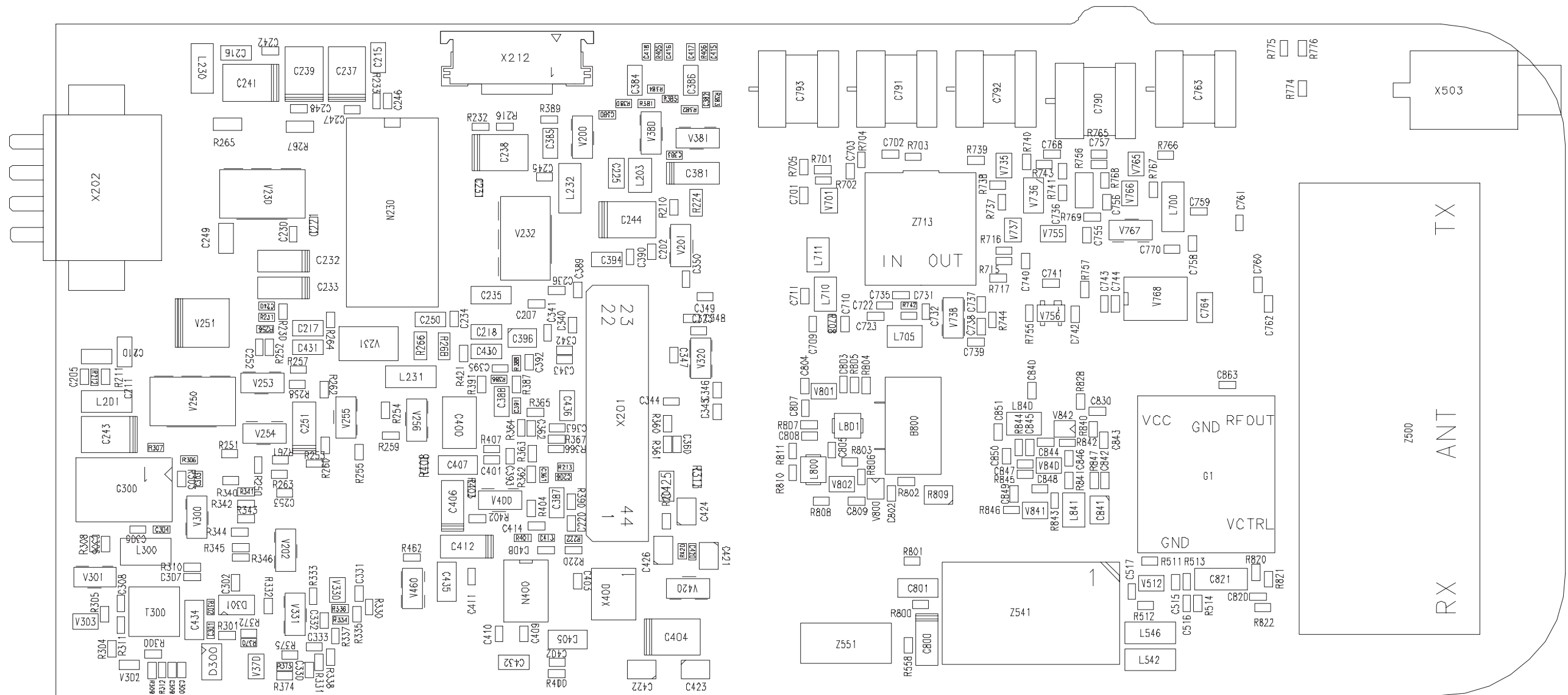

Figure 2 Component Layout – Top

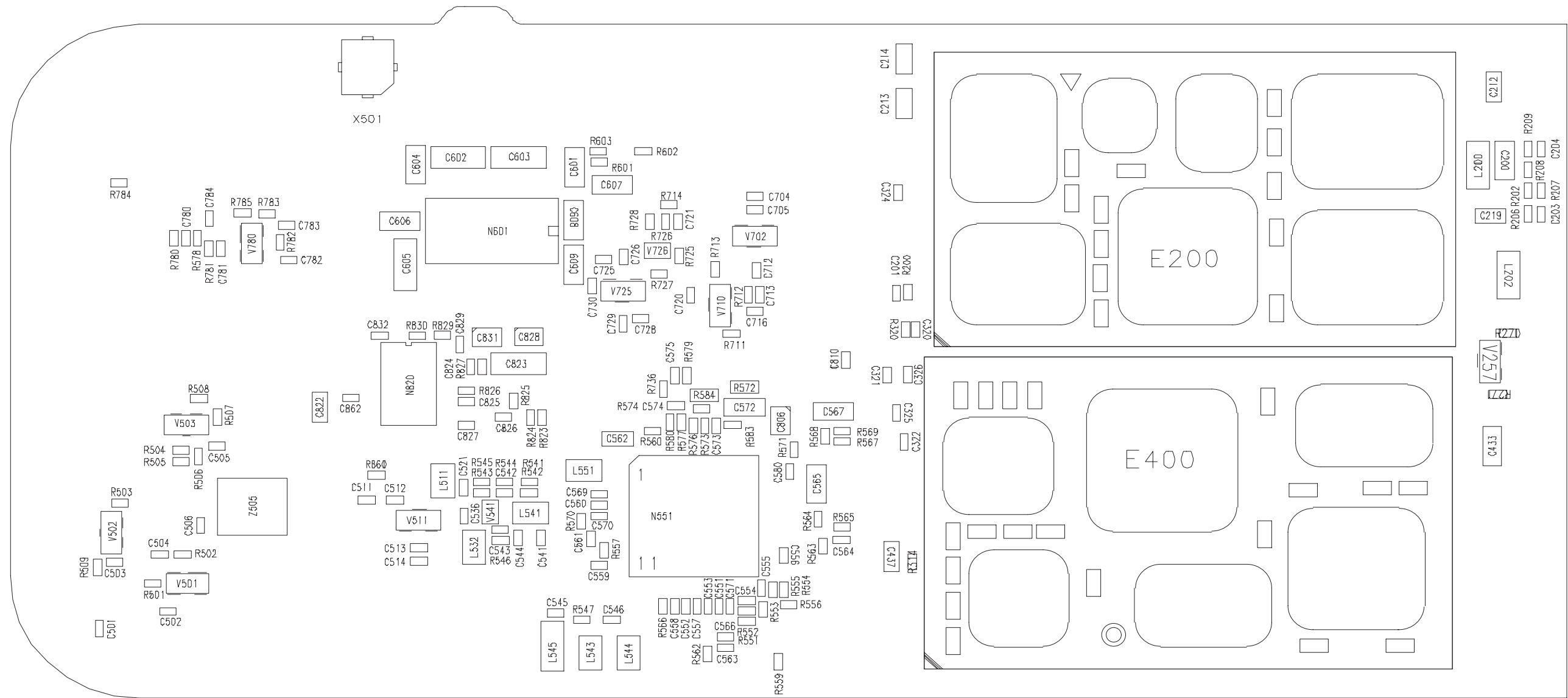

Figure 3 Baseband Circuit Diagram – PWRU

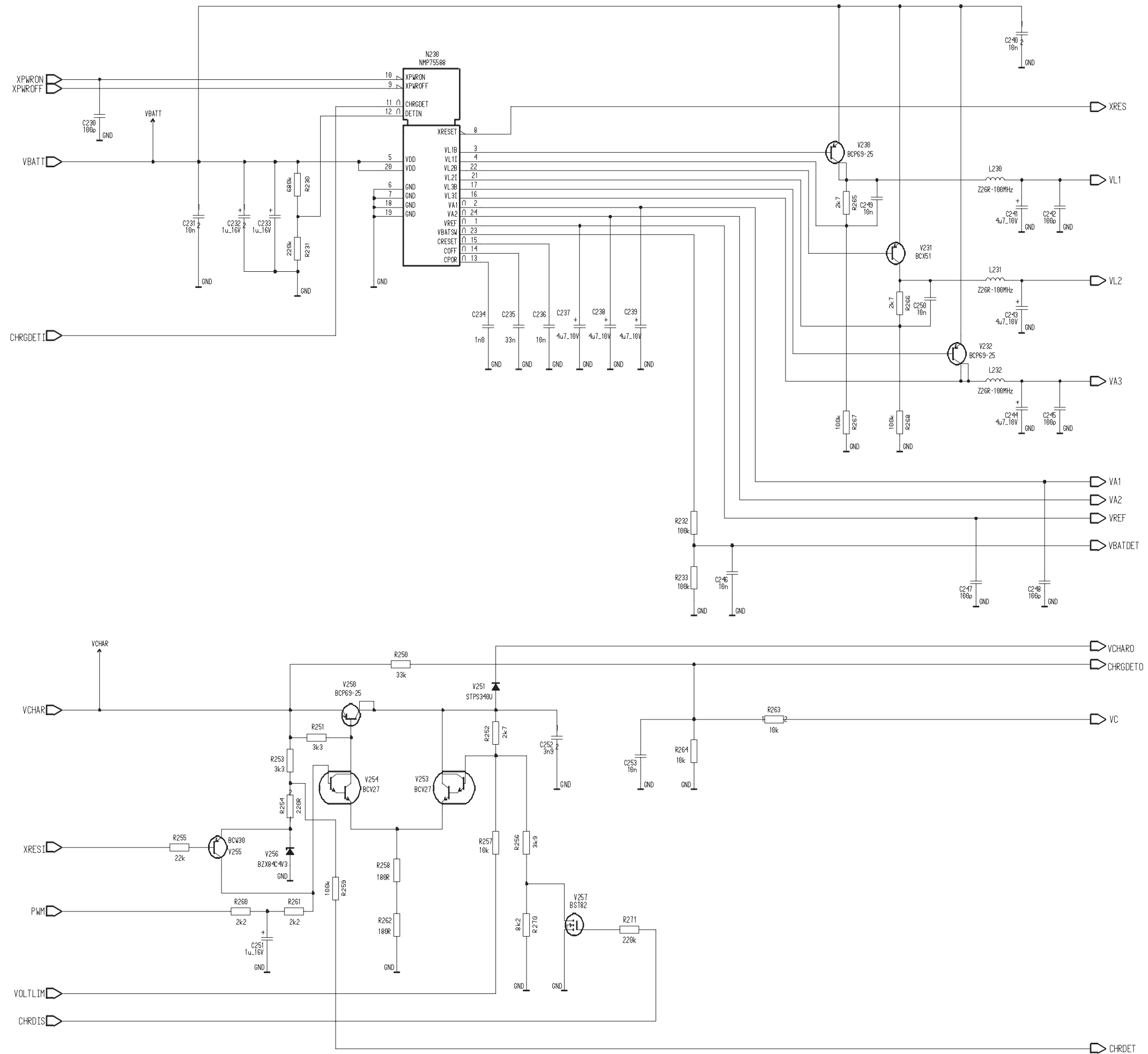

Figure 4 Baseband Circuit Diagram – MCM1

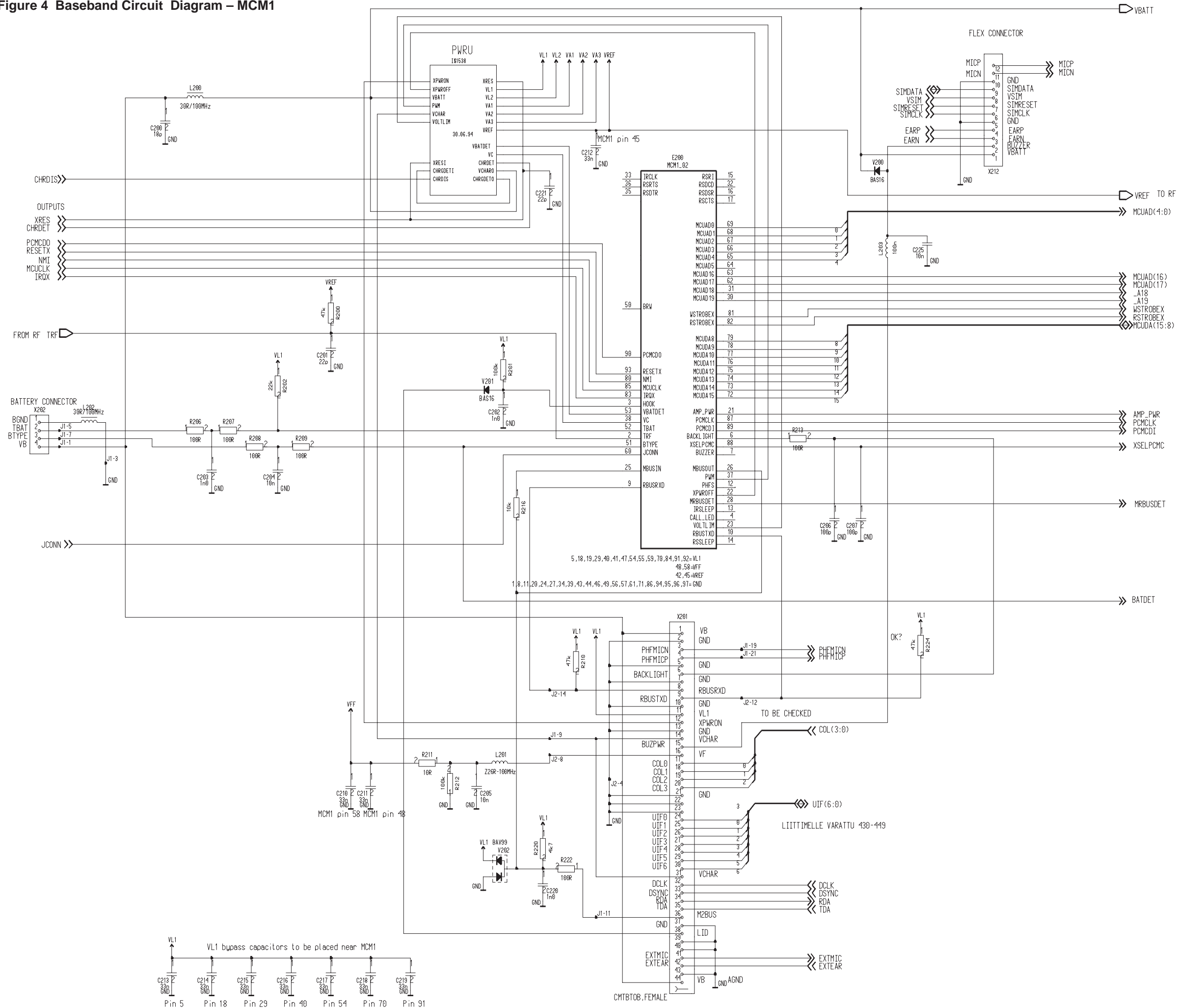

Figure 5 Baseband Circuit Diagram – MCM2

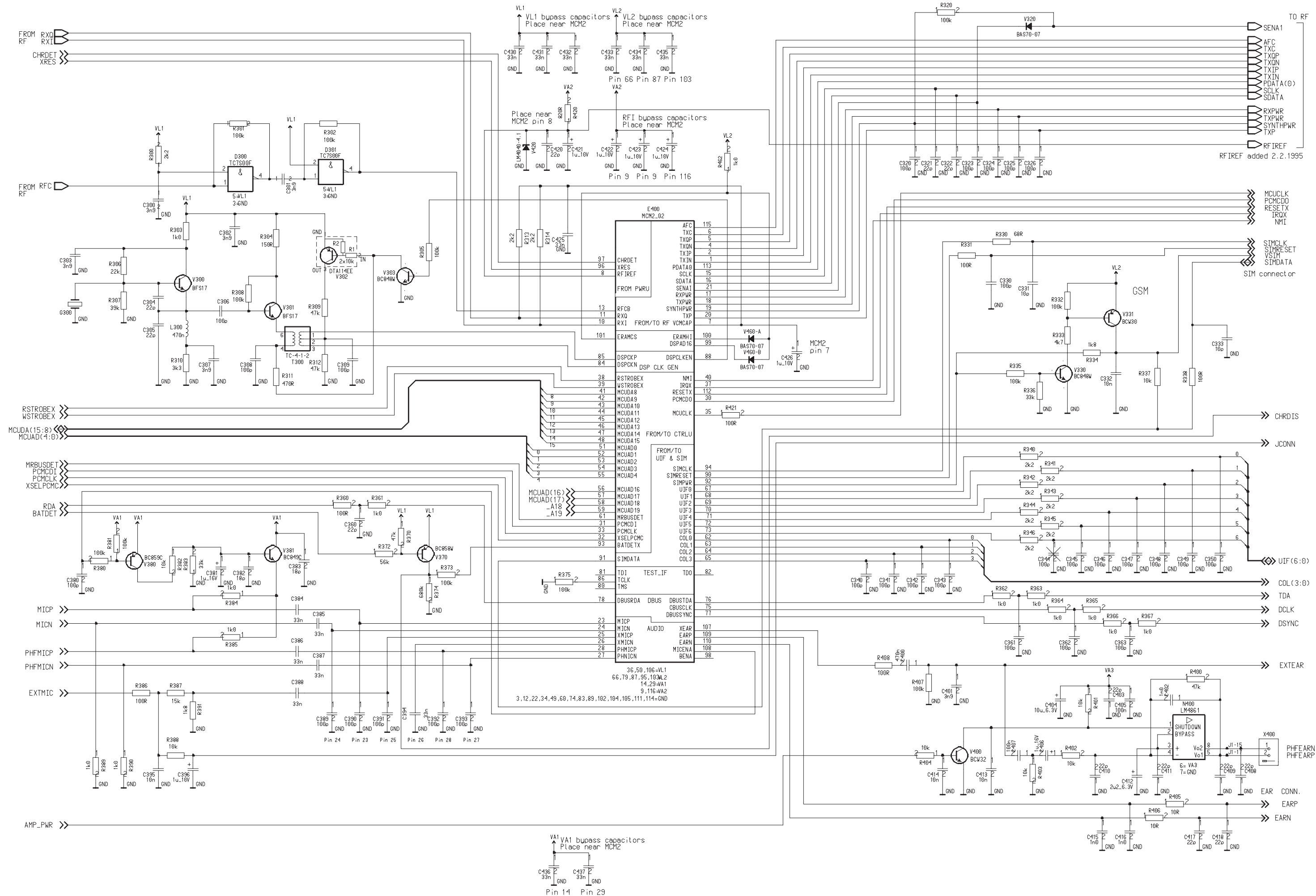

Figure 6 RF / TX Circuit Diagram

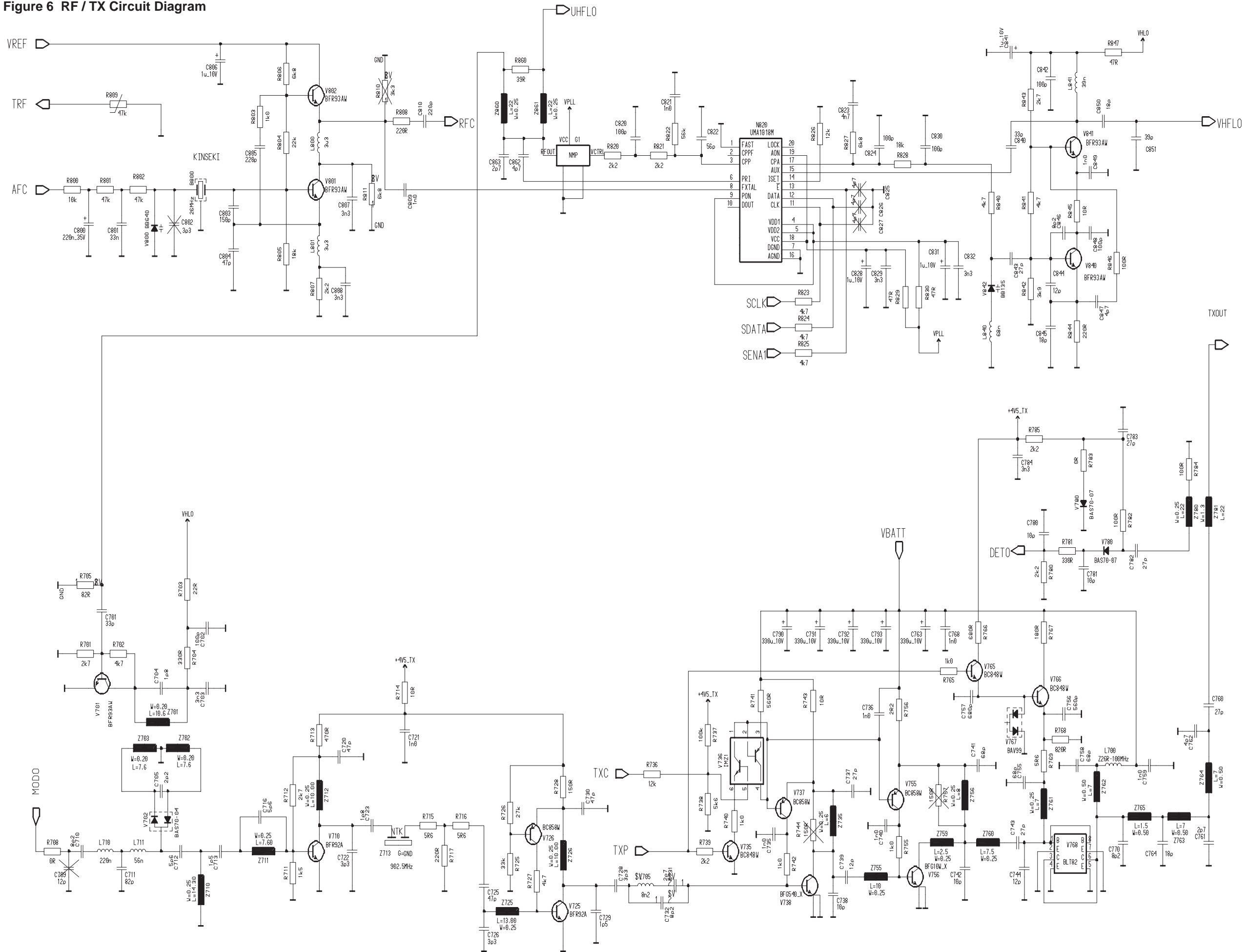

Figure 7 RF / RX Circuit Diagram

